



**NineStar**<sup>®</sup>  
CONNECT



# ELECTRIC SERVICE GUIDE

# TABLE OF CONTENT

- ◆ 3 Member Owned Equipment
- ◆ 4 Application Process
- ◆ 5 Primary Line Extension & New Service Fees
- ◆ 6 Fee Chart
- ◆ 7 Meter Base Information
- ◆ 8 Meter Base Information
- ◆ 9 Meter Base Information
- ◆ 10 Temporary Unit - Overhead Service
- ◆ 11 Temporary Unit - Underground Service
- ◆ 12 Meter on Building - Underground Service 200 AMP
- ◆ 13 Meter on Building - Underground Service 320 AMP
- ◆ 14 Overhead Service - 100 - 200 AMP
- ◆ 15 Meter Pedestal - Underground 200 AMP
- ◆ 16 Meter Pedestal - Underground 320 AMP
- ◆ 17 Street Lighting
- ◆ 18 Street Lighting
- ◆ 19 Tree Trimming
- ◆ 20 Tree Trimming
- ◆ 21 Tree Trimming
- ◆ 22 Tree Trimming
- ◆ 23 Landscape Planning
- ◆ 24 Contact Information

## MEMBER OWNED EQUIPMENT

To eliminate confusion, the drawing depicts member owned equipment necessary for the delivery of electrical power to your home. Safety is our highest priority. If a repair or replacement of member owned service entrance equipment is required, please contact us for a temporary disconnect.

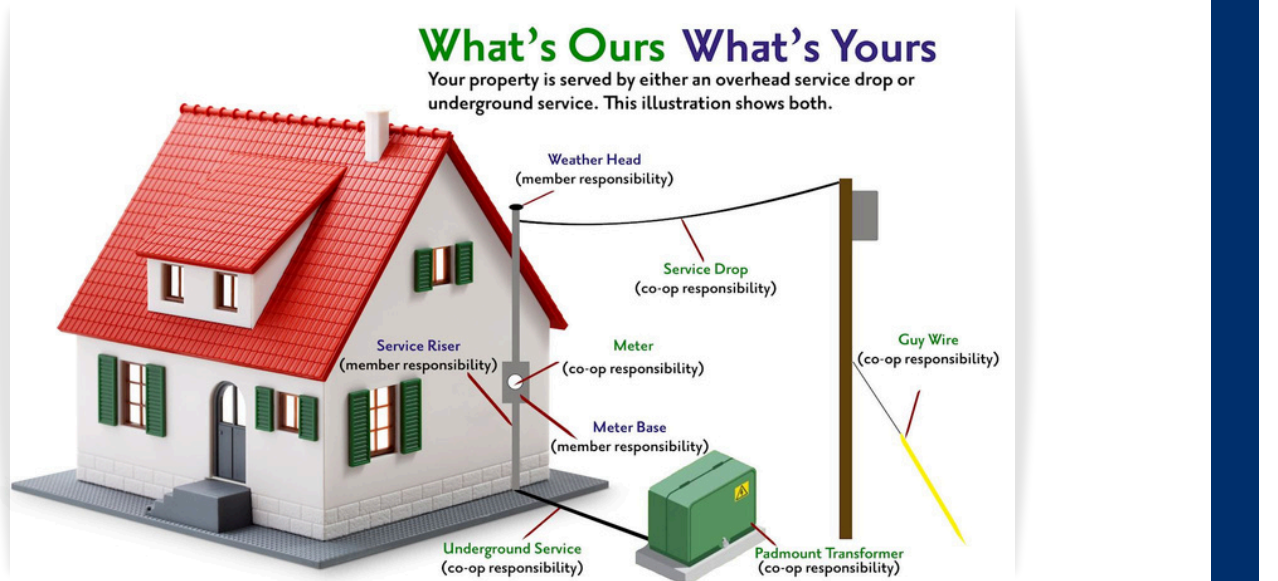

## CALL INDIANA 811 BEFORE YOU DIG

Call 811 to have all utility owned underground facilities located and marked. Privately owned facilities will not be located or marked. Allow at least two full working days but not more than twenty calendar days prior to the start of your excavation to have underground utilities marked. You will need to provide a description of the site, county, township and street address to properly process your locate request.

# Application Process

The NineStar Engineering Department will schedule an appointment for you to meet with one of our staking engineers. During your appointment, you will receive important paperwork and general information.

NineStar requires all necessary paperwork, aid-to-construction costs, and any applicable deposits to be paid in full before the installation of electric service can begin. Required paperwork includes the application for service, an underground agreement, and a right-of-way easement. The signature(s) on the right-of-way easement must match exactly as the property is recorded.

## **PERMITS**

Member/builder is responsible for obtaining all electric permits and inspections required by their respective county.

## **TEMPORARY ELECTRIC SERVICE**

If temporary service is required, the member/builder must provide and install the temporary meter structure. Some counties require inspection of temporary meter structures.

## **PERMANENT ELECTRIC SERVICE**

For permanent installations, member/builder must have meter base installed and inspected by the county building inspector.

## **TEMPORARY TO PERMANENT ELECTRIC SERVICE**

Upon request of member/builder, once the permanent meter base has passed county/city inspection, the staking engineer will visit the job site and flag (if necessary) and inspect for our standards for the permanent service requested. The meter base must be inspected by the county building inspector prior to electric service installation.

## **SERVICE UPGRADES**

Service upgrades and/or relocations generally follow the same protocols as new service installations.

# Fees

## PRIMARY LINE EXTENSION

When figuring the charge for a residential subdivision, single/multi-family fees for primary line extension the following shall apply, whether the streets, roads and alleys of the subdivision have been dedicated as public right-of-way or not.:

- A non-refundable fee of \$2,200 per lot fee shall be charged for installation of residential single-family with lot widths averaging greater than 70-feet.
- A non-refundable fee of \$2,000 per lot fee shall be charged for installation of residential single-family with lot widths averaging 70-feet or less.
- A non-refundable fee of \$1,000 per unit shall be charged for installation of residential multi-family, consisting of 2 to 6 units per structure.
- A non-refundable fee of \$400 per unit shall be charged for installation of residential multi-family, consisting of 7 to 24 units per structure.
- A non-refundable fee of \$300 per unit shall be charged for installation of residential multi-family, consisting of greater than 24 units per structure.

## NEW SERVICE

When figuring the charge for a new service installation the following shall apply:

- A non-refundable fee of \$500 shall be charged for all new single-family residential service installations.
- If a TEMP service hookup is required, there will be an additional \$100 fee in addition to the \$500 new service fee.
- A non-refundable fee of \$350 shall be charged for all new multi-family residential service installations where a ganged-meter base is provided by the party initiating the request. Should multiple single-meter bases be installed for a multi-family structure, the single-family residential installation non-refundable fee of \$500 shall apply.

Fees shall be due upon application for new service. Fees are based on current engineering studies and cost of service studies.

# Fees

Extension Type	PRIMARY	SERVICE
Single-Family Lots (Frontage/Lot <=70')	\$2,000	\$500
Single-Family Lots (Frontage/Lot >=70')	\$2,200	\$500
Multi-Family Low Density (2-6 Units per Building)	\$1,000	\$350
Multi-Family Low Density (7-24 Units per Building)	\$400	\$350
Multi-Family Low Density (25+ Units per Building)	\$300	\$350
Single-Family Primary & Service	CIAC equal to estimate cost of construction less 36-month net revenue credit.	\$500
Single-Family Service		\$500
General Service Primary & Service	CIAC equal to estimate cost of construction less 36-month net revenue credit.	\$500
General Service		\$500
Temporary		\$100

# Meter Base

- Member furnishes and owns the meter base.
- Meter bases must be U.L. approved.
- All single-phase meter bases rated over 100 amps must be equipped with a lever-operated jaw release bypass. The bypass must be rated to carry the full load capacity of the base. (see exhibit A)



Exhibit A

- The minimum width of a 200 amp underground meter base acceptable for use is 11 ¼”.
- All meter bases must have a swing style latch or other appropriate latch that will prevent unauthorized access and accept a utility padlock or wire style seal.
- All meter base installations must be inspected by the appropriate inspecting authority before electrical service can be connected.
- All installation upgrades and re-wiring of meter bases must be inspected by the appropriate authority, if required by the county.
- Meter bases must be installed according to national, state, and county codes, and according to NineStar Connect requirements.
- Meter bases cannot be mounted on homes that do not have permanent foundations. For homes without permanent foundations, bases must be mounted on a meter pedestal.
- Meter bases cannot be located where it will cause a hazard to persons or be subject to damage.
- Meter bases cannot be located in carports, breezeways, enclosed porches, etc. NineStar Connect must have full access at all times.
- Meter bases cannot be installed on NineStar Connect poles.
- For services exceeding 400 amps, a lockable CT cabinet with a minimum size of 3’x3’x14” and a plywood backing is required.
- Meter bases must be continuous amp rating.
- For double lug meter base installations - a disconnect will be required for services to outbuildings, barns, garages, etc.

# Meter Base

- All residential services shall be a minimum of 200 amp.
- If member owned utilities, hazards or obstacles are not marked and are damaged by NineStar Connect or its contractors, it will be the responsibility of the member to repair the damage.
- For three-phase service installations, contact NineStar Connect for specifications.
- Underground services must be installed a minimum of 24" below final grade and maintain meter height at eye level, minimum 4' from final grade and maximum 6' from final grade.
- NineStar Connect must be notified of any hazards or obstacles including member owned utilities (i.e., pipes, septic lines, electrical lines, water lines, etc.) prior to starting construction to extend service overhead or underground. In all cases, obstacles must be clearly marked and/or exposed.
- Bottom of riser for UG service must be exposed for NineStar inspection.
- Only authorized NineStar personnel are permitted to remove or tamper with our meters. Any attempt to remove or alter the meters without proper authorization may result in penalties up to \$500 and service disruptions.
- Maintain clearance around the transformer of at least 10 feet on the side with the doors and a minimum of 3 feet on all other sides. Any obstructions within this area may be removed or damaged during maintenance or service restoration. Keep the area free of anything that could block access including trees, shrubs, debris, etc. (See Exhibit B)



Exhibit B



# Meter Base

## RECOMMENDED METER BASE BRANDS

Equipment must be U.L. Approved.

### The following brands are recommended, but not required:

- Milbank
- Siemens
- Eaton
- GE
- Square D

### Suppliers:

#### Central Supply Company

<https://www.centraisupplycompany.com/search?text=meter%20socket%20lever>

#### Home Depot

<https://www.homedepot.com/b/Electrical-Power-Distribution-Power-Metering-Meter-Sockets/Lever-Bypass/N-5yclvZblzsZ1z20yu0>

#### Menards

<https://www.menards.com/main/electrical/circuit-protection-power-distribution/meter-sockets/c-6439.htm?>

[Spec\\_ProductType\\_facet=Lever+Bypass+Meter+Sockets](#)

#### Kirby Risk - <https://www.kirbyrisk.com/search?>

[q=meter%20socket%20lever&index=kirbyrisk\\_Production\\_Product\\_Default\\_kirbyrisk\\_en-US](https://www.kirbyrisk.com/search?q=meter%20socket%20lever&index=kirbyrisk_Production_Product_Default_kirbyrisk_en-US)

# Temporary Overhead Unit

## TEMPORARY SERVICE

### TEMPORARY OVERHEAD SERVICE CONSTRUCTION 120/240 VOLT 60 TO 100 AMP SINGLE PHASE

- 1) Existing or proposed utility pole.
- 2) Weatherhead and conduit, with 36 inches of service entrance conductor stubbed out.
- 3) Views of required braces and stakes.
- 4) Service drop and wire holder supplied by the utility.
- 5) Minimum 4 inch x 4 inch structure.
- 6) Meter base.
- 7) Fused disconnect.
- 8) Ground rod 1/2 inch x 8 feet copper clad (min) and one-bolt ground rod clamp.
- 9) The minimum service entrance conductor size shall be #6 CU.

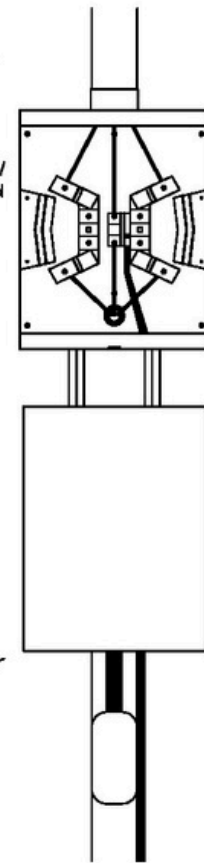
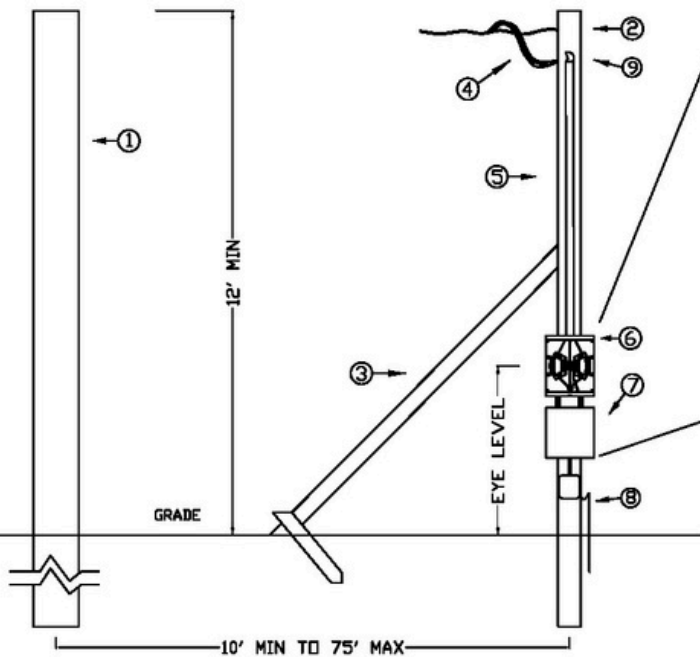

ENLARGEMENT

HOLEY MOLEY



CALL BEFORE YOU DIG  
1-800-382-5544



(317)326-3131

Drawn: 5/2/2004 JMB

Revised: 4/14/2004 JMB

# Temporary Underground Unit

## TEMPORARY SERVICE

### UNDERGROUND TEMPORARY SERVICE AT PADMOUNT TRANSFORMER

- 1) Existing pad mount transformer.
- 2) Threaded flex conduit adapter, reducing washers, and locknut with 36" of service conductor stubbed out.
- 3) Flex conduit.
- 4) Meter base.
- 5) Disconnect and service equipment with GFI.
- 6) Ground wire, wire size #6 CU
- 7) Ground rod, 1/2" copper clad 8', and one-bolt ground rod clamp.

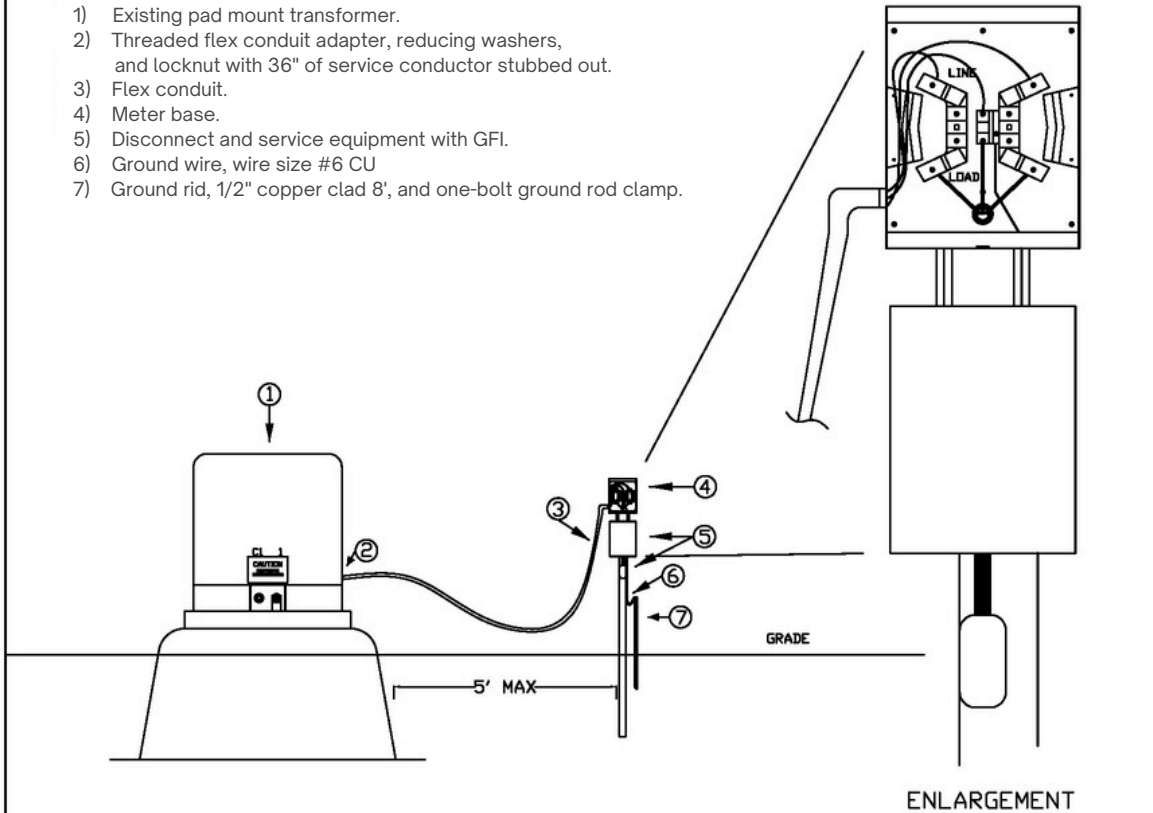

HOLEY MOLEY



CALL BEFORE YOU DIG  
1-800-382-5544



(317)326-3131

Drawn: 3/2/2004 JTP

Revised: 1/15/20 R11

# Meter on Building

## UNDERGROUND SERVICE 200 AMP SINGLE PHASE 120/240 VOLT

IT IS YOUR RESPONSIBILITY FOR LOCATING ANY WATER OR SEWER LINES, SPRINKLER SYSTEMS, ETC. WITHIN CENTRAL INDIANA POWER'S PROPOSED "FLAGGED" TRENCH ROUTE. PLEASE NOTIFY CIP OF ANY BURIED FACILITIES THAT COULD PRESENT A PROBLEM WHEN INSTALLING YOUR SERVICE LINE.

- 1) Meter base with four screws securing base.
- 2) Minimum 2 inch schedule 40 PVC riser.
- 3) Ground conduit. If EMT, shall bond at both ends.
- 4) 8' long ground rod 1/2" and clamp. Ground #4 Copper at panel or meter base but not both.
- 5) Two (2) straps evenly spaced on riser.
- 6) Base of riser needs to be exposed.

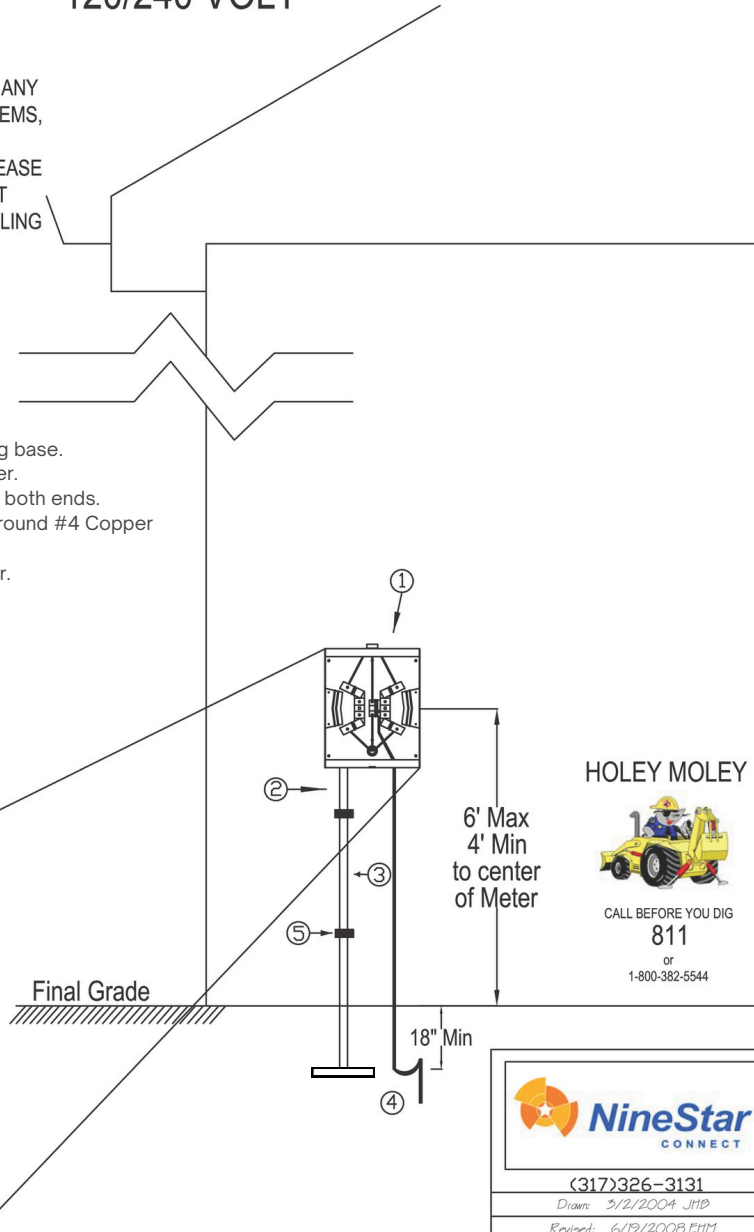
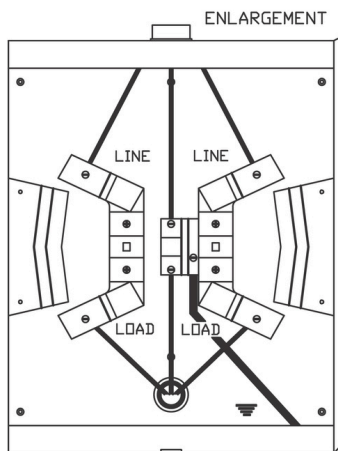

HOLEY MOLEY



CALL BEFORE YOU DIG  
811  
or  
1-800-382-5544



(317)326-3131

Drawn: 3/2/2004 J11P

Revised: 6/19/2008 E111

# Meter on Building

## UNDERGROUND SERVICE 320 AMP SINGLE PHASE 120/240 VOLT

IT IS YOUR RESPONSIBILITY FOR LOCATING ANY WATER OR SEWER LINES, SPRINKLER SYSTEMS, ETC. WITHIN NINESTAR'S PROPOSED "FLAGGED" TRENCH ROUTE. PLEASE NOTIFY NINESTAR OF ANY BURIED FACILITIES THAT COULD PRESENT A PROBLEM WHEN INSTALLING YOUR SERVICE LINE.

- 1) Meter base with four screws securing base.
- 2) Minimum 3 inch schedule 40 PVC riser.
- 3) Ground conduit. If EMT, shall bond at both ends.
- 4) 8' long ground rod 1/2" and clamp. Ground #4 Copper at panel or meter base but not both.
- 5) Two (2) straps evenly spaced on riser.
- 6) Base of riser needs to be exposed.

*Enlargement*

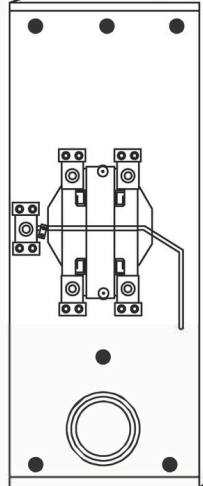

Final Grade

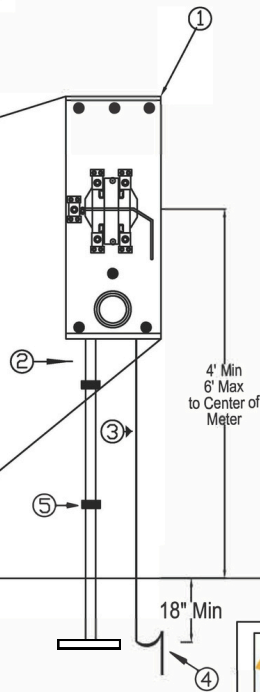

HOLEY MOLEY



CALL BEFORE YOU DIG  
**811**  
or  
1-800-382-5544



(317)326-3131

Drawn: 3/2/2004 JH1P

Revised: 6/16/08 EHM

# Overhead Service

OVERHEAD SERVICE, HOUSE ATTACHMENT,  
100-200 AMP, 120-240 VOLT, SINGLE PHASE  
(NON LOAD BEARING RISER)

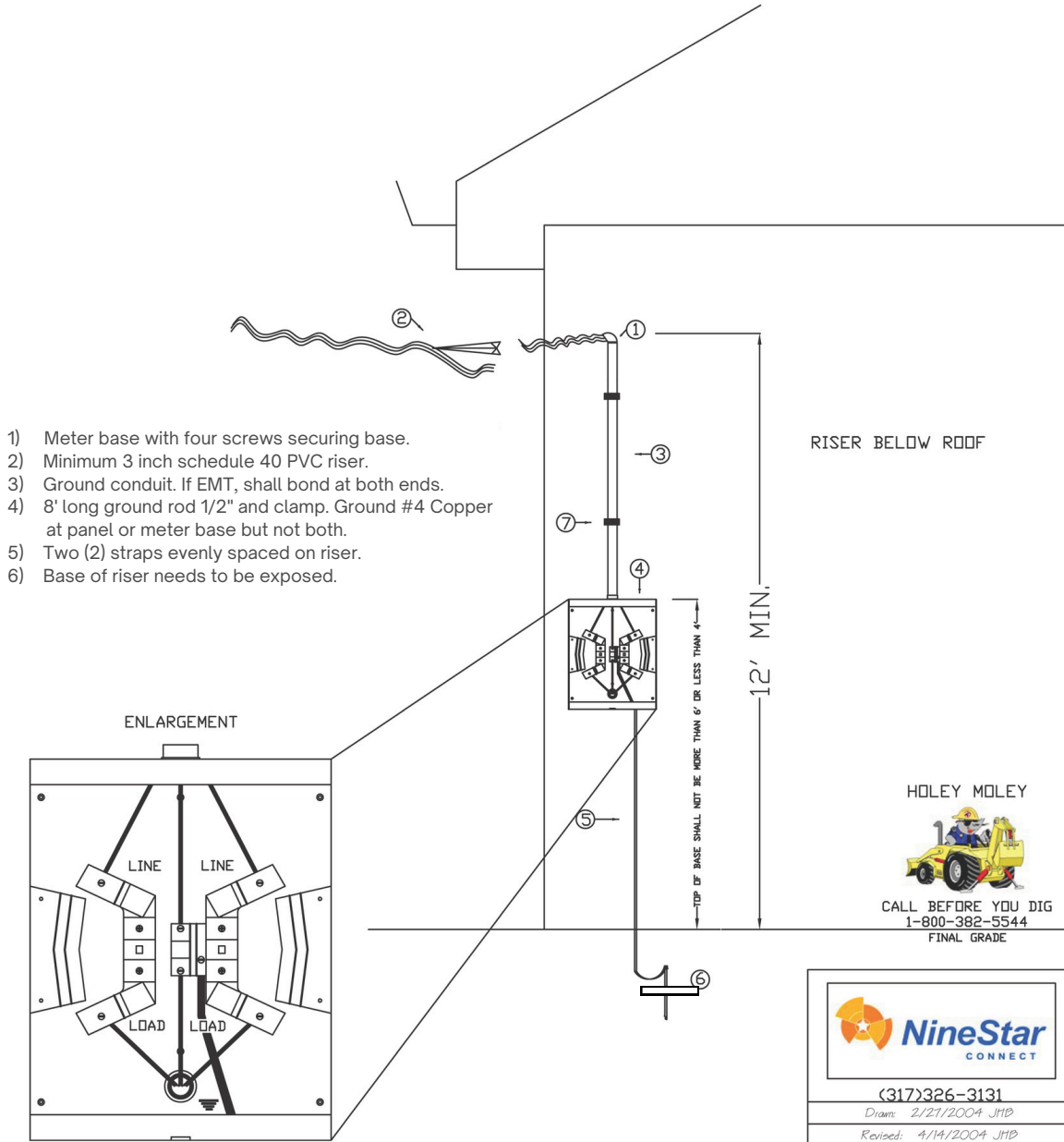

# Meter Pedestal

## UNDERGROUND METER PEDESTAL INSTALLATION, SINGLE PHASE, 120/240 VOLT, 200 AMP

- 1) Minimum 4" x 4" treated wood posts.
- 2) Meter base with four screws securing base.
- 3) Minimum 1/2" thick treated wood backing.
- 4) Minimum 3" schedule 40 pvc riser for service entrance conductors.
- 5) Outside fused rain tight disconnect.
- 6) If ground wire is installed in conduit (metal conduits must be bonded at both ends to grounding conductor) service may be grounded at panel or meter base but not both. Install ground rod and attach ground wire to rod with a one-bolt ground rod clamp (water pipe clamps not acceptable). #4 STD
- 7) 1/2" copper clad 8'
- 8) Two (2) straps evenly spaced on riser.
- 9) Base of riser needs to be exposed.

IT IS YOUR RESPONSIBILITY FOR LOCATING ANY WATER OR SEWER LINES, SPRINKLER SYSTEMS, ETC. WITHIN CENTRAL INDIANA POWER'S PROPOSED "FLAGGED" TRENCH ROUTE. PLEASE NOTIFY CIP OF ANY BURIED FACILITIES THAT COULD PRESENT A PROBLEM WHEN INSTALLING YOUR SERVICE LINE.

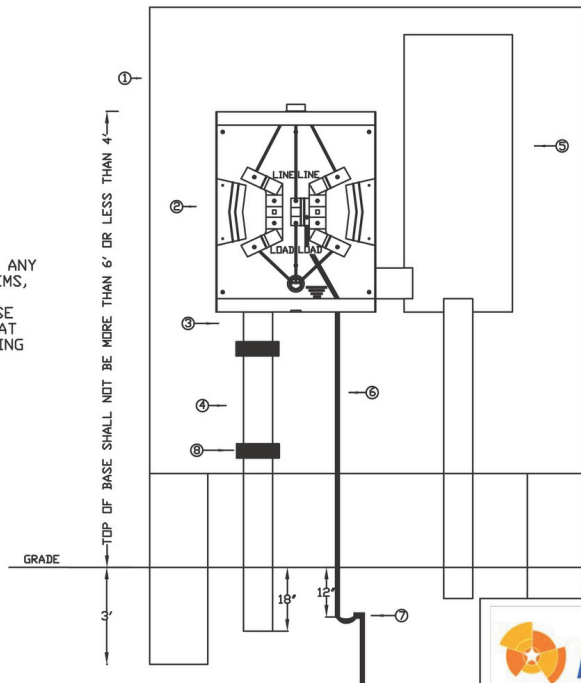

HOLEY MOLEY



CALL BEFORE YOU DIG  
1-800-382-5544



(317)326-3131

Drawn: 2/8/2004 J1P

Revised: 6/16/2021 RH

# Meter Pedestal

## UNDERGROUND METER PEDESTAL INSTALLATION, SINGLE PHASE, 120/240 VOLT, 320 AMP

- 1) Minimum 4" x 6", 1.5" thick treated wood posts.
- 2) Meter base with four screws securing base.
- 3) Minimum 1/2" thick treated wood backing.
- 4) Minimum 3" schedule 40 pvc riser for service entrance conductors.
- 5) Outside fused rain tight disconnect.
- 6) If ground wire is installed in conduit (metal conduits must be bonded at both ends to grounding conductor) service may be grounded at panel or meter base but not both. Install ground rod and attach ground wire to rod with a one-bolt ground rod clamp (water pipe clamps not acceptable). #4 CU
- 7) 1/2" copper clad 8'
- 8) Two (2) straps evenly spaced on riser.
- 9) Base of riser needs to be exposed.

IT IS YOUR RESPONSIBILITY FOR LOCATING ANY WATER OR SEWER LINES, SPRINKLER SYSTEMS, ETC. WITHIN CENTRAL INDIANA POWER'S PROPOSED "FLAGGED" TRENCH ROUTE. PLEASE NOTIFY CIP OF ANY BURIED FACILITIES THAT COULD PRESENT A PROBLEM WHEN INSTALLING YOUR SERVICE LINE.

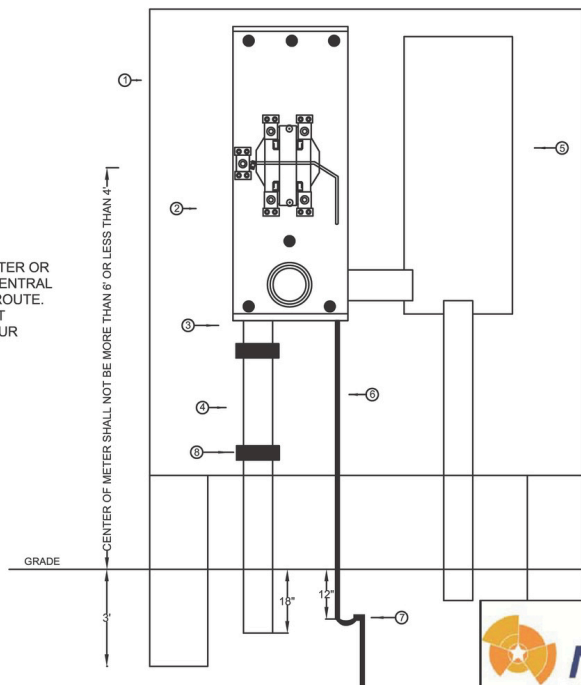

HOLEY MOLEY



CALL BEFORE YOU DIG  
1-800-382-5544



(317)326-3131

Drawn: 2/8/2004 J1P

Revised: 12/15/2011 RH



# Street Lighting

## 1. Streetlight pedestal at pad mount transformer

- a. Already an existing pad mount transformer
- b. The installation of the disconnect pedestal and service equipment must be performed by a licensed electrician hired by the party requesting the service
- c. The service conductor needs to run to transformer pad with appropriate wire size matching breaker in the disconnect, leaving a minimum of 5' of conductor exposed at the pad.
- d. Ground wire must be a minimum #6 CU
- e. ½"x8' copper clad ground rod must be installed with a one-bolt ground rod clamp.
- f. The pedestal shall be located behind the transformer to one side and no more than 5' away.
- g. No plug-in outlets are allowed to be fed from pedestal
- h. Recommended disconnect is (Milbank U5200-xl or comparable unmetere enclosure with disconnect)
- i. Diagram (See exhibit C) 1. Pad mount transformer 2. Disconnect and service equipment 3. Service conductor 4. Ground Wire 5. Ground rod

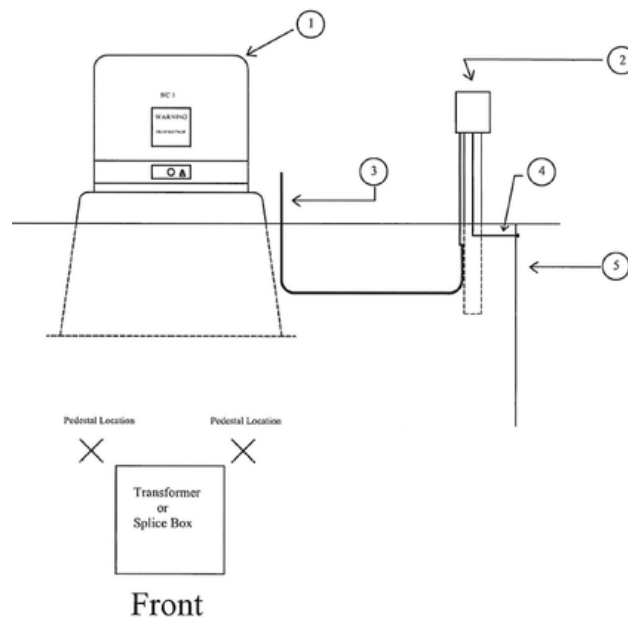

Exhibit C

# Street Lighting

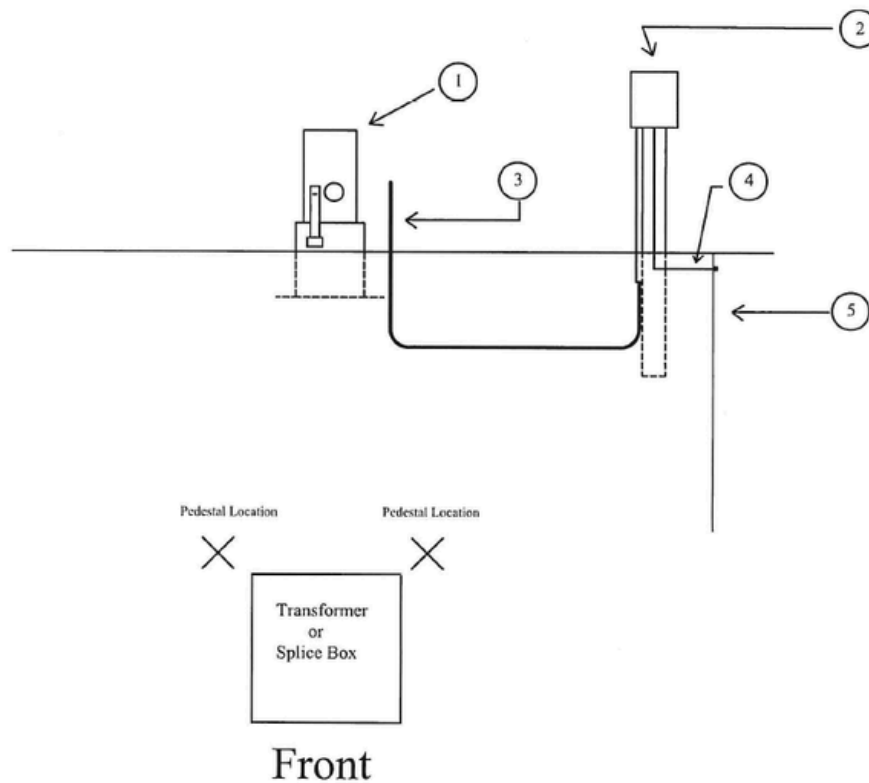

Exhibit D

## 2. Streetlight pedestal at secondary splice box :

- a. Already an existing secondary splice box.
- b. The installation of the disconnect pedestal and service equipment must be performed by a licensed electrician hired by the party requesting the service
- c. The service conduct needs to run to secondary pad with appropriate wire size matching breaker in the disconnect, leaving a minimum of 5' of conductor exposed at the pad.
- d. Ground wire must be a minimum #6 CU
- e.  $\frac{1}{2}$ "x8' copper clad ground rod must be installed with a one-bolt ground rod clamp.
- f. The pedestal shall be located behind the splice box to one side and no more than 5' away.
- g. No plug-in outlets are allowed to be fed from pedestal
- h. Recommended disconnect is (Milbank U5200-xl or comparable un-metered enclosure with disconnect)
- i. Diagram (See exhibit D) 1. Secondary splice box 2. Disconnect and ser equipment 3. Service conductor 4. Ground Wire 5. Ground rod

# Tree Trimming

## Steps for requesting tree trimming from NineStar Connect

### 1. Identify the Affected Line:

- Determine if the vegetation is impacting primary power lines, which are eligible for trimming requests.
- Refer to (Exhibit E) to distinguish between primary power lines and other types.

### 2. Submit a Tree Trimming Request:

- If a primary power line is affected, call 317-323-3131 to submit a request.

### 3. Await Follow-Up:

- A vegetation management professional from NineStar Connect will contact you within 5 business days to assess the situation.

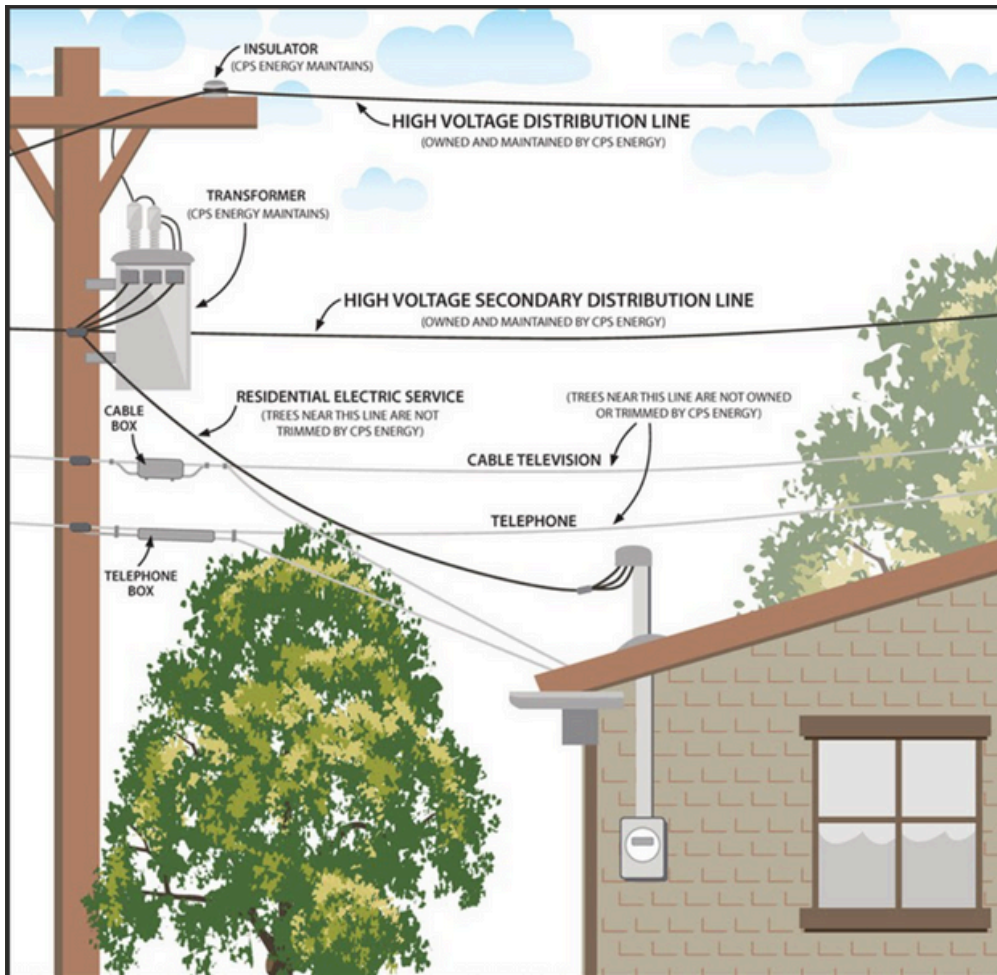

Exhibit E

# Tree Trimming



## Important Considerations

- **Non-Eligible Requests:**

- Requests may be denied or deferred if:
  - Vegetation isn't currently affecting power reliability and can wait until the next scheduled maintenance.
  - Vegetation impacts cable or telephone lines but not power lines.
  - Vegetation affects the light pattern of outdoor lights without compromising power reliability.
  - Vegetation is near a service drop (the line from the pole to your property). In this case, contact NineStar Connect Customer Service to have the line de-energized before any tree work.

- **Emergency Situations:**

- If a tree has fallen onto a primary power line, it constitutes an emergency. Contact NineStar Connect immediately by phone at 317-323-3131 for immediate assistance.

- **Debris Cleanup:**

- In maintained areas, NineStar Connect disposes of small limbs and brush. Larger wood pieces are cut but may not be firewood length.
- In unmaintained areas, pruned vegetation is left to biodegrade.
- Debris from storm damage or natural events is the property owner's responsibility to remove.

# Tree Trimming

## Right-of-Way Maintenance & Access

Trees growing close to overhead power lines pose safety concerns and can disrupt reliable electricity. Falling branches or trees are a leading cause of power outages and brief service interruptions. Also, when a tree comes into contact with a power line, it can conduct electricity, increasing the risk of electrical hazards, fires, and property damage. Regular trimming and removal of trees near power lines are crucial to maintaining safe and dependable service for NineStar Connect customers.

## Scheduled Maintenance

To ensure the safety and reliability of your electric service, NineStar Connect conducts regular tree trimming and right-of-way maintenance to manage vegetation near overhead power lines. This work is performed by trained NineStar Connect staff and professional contractors. We greatly appreciate your cooperation with these efforts, which play a vital role in preventing outages and maintaining a safe environment. A qualified arborist and experienced utility contractor assess vegetation encroaching on power lines and will provide homeowners with a door tag outlining the planned work. (see Exhibit F)



**Sorry we missed you...**

Our goal at NineStar Connect Electric Division is to provide you with safe and reliable electric service. Controlling plant growth near power lines is an important part of achieving this goal.

Today, our arborist stopped by to talk with you about line clearance work on or near your property. Information about our work is indicated on the back of this card. If you would like to discuss this, please feel free to contact us at the number below. If you cannot reach us, please leave your name, address, phone number, and a good time to reach you.

Name: \_\_\_\_\_

Phone: \_\_\_\_\_

**Voicemail: 317-323-2633**

*If we do not hear from you, we will proceed as outlined on the reverse side.*





We are currently in the planning stage for our upcoming line clearance work. The following checklist details the work to be done on your property.

- Work has not been marked at this location. Please contact our office.
- Small trees marked with a painted slash are scheduled for removal.
- We have identified trees on your property that are scheduled for removal with a painted X.
- Trees marked with a painted dot are scheduled for trimming.

\_\_\_\_\_

\_\_\_\_\_

\_\_\_\_\_

This work will be completed at the Ninestar Connect's Electric Division's expense. As a convenience to you, the small branches will be removed and the larger wood will be cut into manageable pieces and left for your use or disposal. After trimming, we plan to return every 36-60 months to evaluate your tree's growth and health.

Thank You!

\_\_\_\_\_

\_\_\_\_\_

\_\_\_\_\_

\_\_\_\_\_

\_\_\_\_\_

Exhibit F

# Landscape Planning

## Landscape Planning

You can help maintain safe and clear rights-of-way by carefully planning your landscaping:

- **Overhead Lines:**

- If you are planning tree trimming at your home, we will lower your overhead service line at no charge during normal business hours. To arrange this, please call 317-326-3131 and ask to speak with our operations team.
- Plant trees and shrubs at least 20 feet away from power lines.
- Select small trees (e.g., dogwoods or fruit trees) that won't grow tall enough to interfere with power lines. (see Exhibit G)

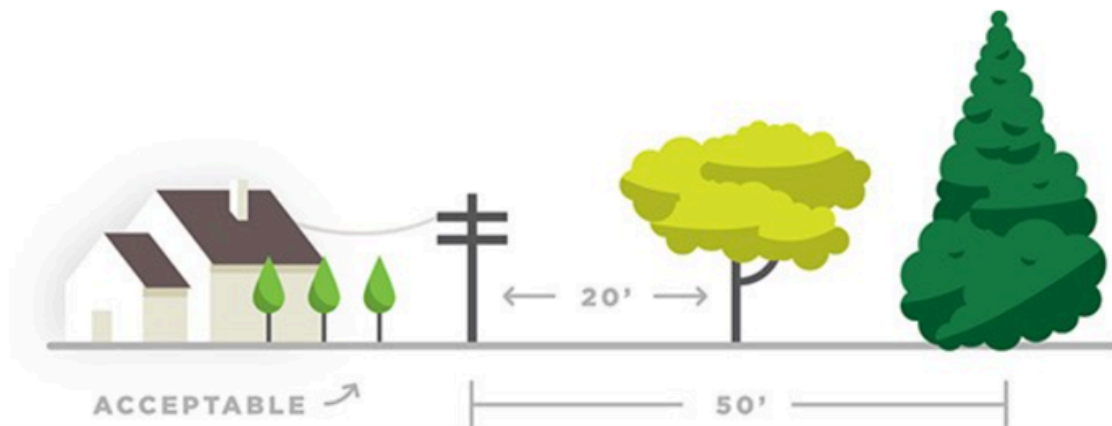

Exhibit G

# Landscape Planning

You can help maintain safe and clear rights-of-way by carefully planning your landscaping:

- **Underground Lines:**

- Keep plants and shrubs at least 3 feet away from electrical equipment enclosures. Access to these enclosures must remain clear for safety and maintenance purposes.

By maintaining rights-of-way and following these guidelines, NineStar Connect ensures a safe and reliable delivery of electricity while working with customers to address specific concerns.

### Utility-Friendly Tree List

The following list includes overhead utility-friendly (low-growing) tree species which may be compatible in areas of overhead utility lines. This list is not all-inclusive. Other species may be acceptable and each selection should be considered for mature size in relationship to the height of the overhead lines. Consult a utility forester or your provider for assistance. Be sure to comply with local regulations and ordinances. Size noted is typical for urban conditions; mature sizes should be less than 20 feet in most applications.

Species	H'	W'	Shape	Light	Description
<b>Paperbark Maple</b> ( <i>Acer griseum</i> )	25	20	Upright, oval to rounded	Full sun to part shade	Trifoliate leaves, bright red and orange fall color; cinnamon brown to reddish brown exfoliating bark.
<b>Shadblow Serviceberry</b> ( <i>Amelanchier canadensis</i> )	20	20	Oval to rounded	Full sun to part shade	White flowers in spring; red to purple fruit; yellow mixed with a little orange fall color.
<b>Apollo Maple</b> <i>Acer saccharum</i> "Barrett Cole"	25	10	Narrow, columnar	Full sun to part shade	Unique narrowness, dense branching and compact form make this dwarf and columnar Sugar Maple ideal for limited spaces. Dark green foliage withstands summer heat.
<b>Autumn Brilliance Serviceberry</b> ( <i>Amelanchier x grandiflora</i> "Autumn Brilliance")	20	20	Rounded	Full sun to part shade	White flowers in spring; red to purple fruit; orange to red fall color.
<b>Allegheny Serviceberry</b> ( <i>Amelanchier laevis</i> )	20	20	Upright, irregular	Full sun to part shade	White flowers in spring; red to purple fruit; late yellow to orange fall color.
<b>Eastern Redbud</b> ( <i>Cercis Canadensis</i> )	25	25	Upright, spreading	Full sun to part shade	Early pink flowers along twig before foliage; heart-shaped leaves.
<b>Pagoda Dogwood</b> ( <i>Cornus alternifolia</i> )	20	20	Rounded	Full sun to part shade	Horizontal branching; creamy-white flowers followed by blue-black fruit; red to purple fall color.
<b>Cornelian Cherry Dogwood</b> ( <i>Cornus mas</i> )	20	15	Rounded	Full sun to part shade	Early yellow flowers before foliage; bright red fruit in summer.
<b>Cockspur Hawthorn</b> ( <i>Crataegus crus-galli</i> )	20	20	Broad, rounded	Full sun	Showy, white flowers; red fruit; glossy foliage; thorny; attracts birds.
<b>Thornless Cockspur Hawthorn</b> (var. <i>inermis</i> )	20	20	Broad, rounded	Full sun	Thornless; other characteristics same as species.
<b>Washington Hawthorn</b> ( <i>Crataegus phaenopyrum</i> )	25	25	Upright, spreading	Full sun	White flowers; showy, orange-red fruit; red-orange fall color; narrow thorns.
<b>Royal Star Magnolia</b> ( <i>Magnolia kobus</i> var. <i>stellata</i> "Royal Star")	15	15	Oval to rounded	Full sun to part shade	White flowers with pink in early spring before leaves.
<b>Crabapple</b> ( <i>Malus</i> spp.)					
"Sugar Tyme"	20	15	Upright, oval	Full sun	Pink buds; white flowers; red fruit.
"Centurion"	20	15	Upright	Full sun	Pink to red flowers; red fruit; red to bronze foliage.
"Donald Wyman"	20	25	Broad, rounded	Full sun	Pink to red buds open to white flowers; red fruit.
"Indian Summer"	15	15	Rounded	Full sun	Red buds; rose-red flowers; red fruit.
"Snow Drift"	20	15	Rounded	Full sun	Red bud; white flowers; small red fruit.
"Prairiefire"	20	20	Upright, rounded	Full sun	Pink flowers; red fruit.
<b>Ivory Silk Japanese Tree Lilac</b> ( <i>Syringa reticulata</i> )	20	15	Rounded	Full sun	Creamy panicles of fragrant flowers in late spring; red-brown shredding bark.
<b>Techy Arborvitae</b> <i>Thuja occidentalis</i>	15	6	Upright, pyramidal	Full sun to part shade	Fast growing and dark green. Excellent for screens and tall sheared hedges. Good in sun or light shade. Very winter hardy.
<b>Keteleeri Juniper</b> <i>Juniperus chinensis</i> "Keteleeri"	20	10	Upright, pyramidal	Full sun	Dense evergreen tree with medium green, mostly scale-like foliage which is attractive year-round. This is a female cultivar that produces profuse, grayish-green, berry-like cones.
<b>Hetz Columnar Juniper</b> <i>Juniperus chinensis</i> "Hetzi Columnar"	15	8	Upright, pyramidal	Full sun	Multi-stemmed evergreen tree with bright green foliage and abundant bluish-green berries.

# CONTACT US



 [ninestarconnect.com](https://www.ninestarconnect.com)

 317-326-3131

 [operations@ninestarconnect.com](mailto:operations@ninestarconnect.com)

 2243 E Main St. • Greenfield